

SmartBright Street

PHILIPS

Street Light

SmartBright Street



1400lm
1900lm



Finless Design

Applications



Residential



Security



Parks

Other applications : Periphery, Residential garden, Footpath, Car park, Gated Community...

Reliable Savings, lasting brightness

High performance in a robust and compact design

Unique Selling Points:

- Up to 70% energy savings
- Unique finless design
- Polycarbonate cover with high impact resistance as compared to glass cover
- Robust die-cast aluminum housing
- Optimized Road lighting distribution
- IP65 water & dust protection
- Long life as compared to FL/CFL street light
- System power 15W & 20W options
- 1 to 1 replacement for 40W FL/36 CFL street light

Integrated optics

Uniform lighting on street

100-270V supply range

Wide operating voltage

Finless design

Superior aesthetic looks

Features and benefits

Reliable Savings, lasting brightness
High performance in a robust and compact design

Use with peace of mind

- 4KV Surge Protection
- IK07 classification
- IP65 certified



Long-lasting performance

- Designed for energy savings of up to 70% compared with conventional lighting
- L70 30k hours*
- Designed for operations under diverse environment from -40°C to 45°C

**Designed to sustain 70% of initial lumen output (L70) at 30,000 hours of lifetime*

High-quality materials and design

- Finless design with superior aesthetic looks
- Toughened and shatter-proof quality built-in lens enhances safety
- Pressure die-cast housing offers excellent corrosion-resistance and robustness

Detailed Specification

Optical Distribution for Road Applications

Model name	BRP042
Product hierarchy	A47 644401
Power	15W / 20W
Lumen output	1400lm / 1900lm
CCT	5700K
CRI	70 Min
System Efficacy	95lm/w
Insulation classification	Class I
Connection	300mm fly wire
Rated Power Supply	220 – 240V 50Hz
Operational Range	100 - 270V/ 50Hz
Power factor	0.95
IP rating	IP65
IK rating	IK07
Surge protection	4KV
Lifetime	30,000 hrs @Ta 35°C
Ambient Temp	-40~45°C
Dimension	316 x 107 x 60mm
Weight	0.85kg
Installation	φ 28 - 40mm Side Entry
Housing Colour	RAL7011
Certificate	IEC CB

BRP042 LED14 CW MR S1 PSU GR.PHL

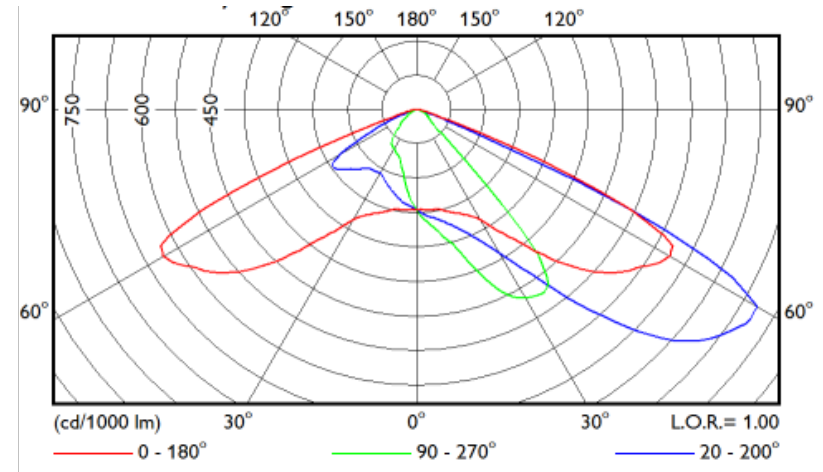

BRP042 LED19 CW MR S1 PSU GR.PHL

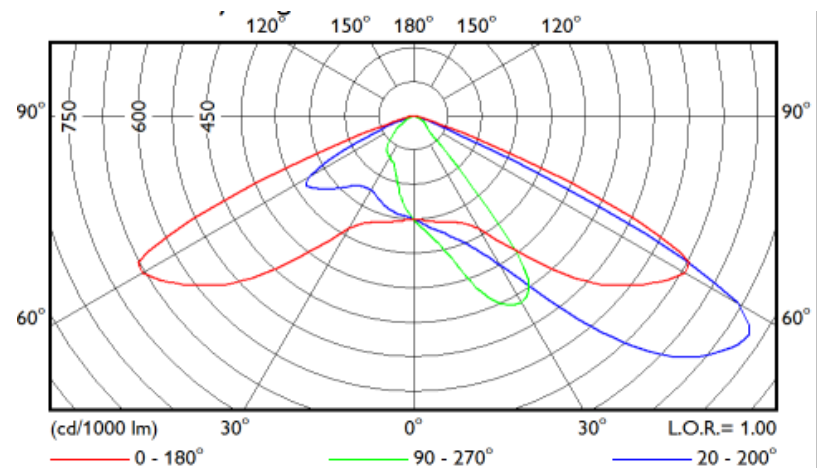

Note :

- All are nominal values at Nominal operating voltage 220 -240V and will vary +/-10%
- This is a non-serviceable product

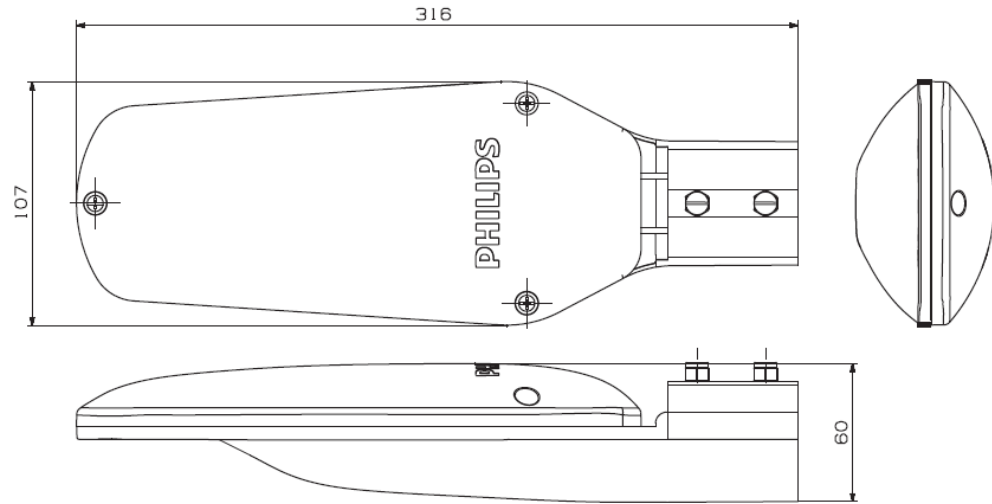

Side Entry

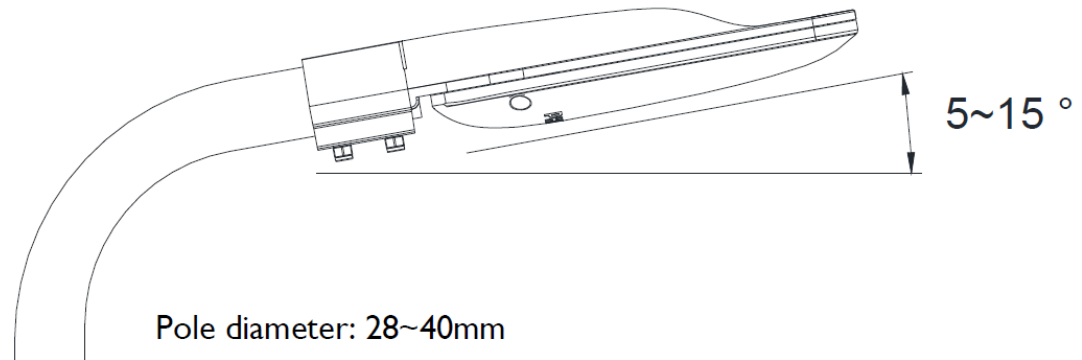

Ordering Information

12NC	Description	Lumen Package (lm)	Power	Lm/W
919515811876	BRP042 LED 14/CW 15W MR S1 PSU GR	1,400	15W	93
919515811877	BRP042 LED 19/CW 20W MR S1 PSU GR	1,900	20W	95

Package in full colour

With USP's and Mounting Instruction





SmartBright Street

SmartBright street offers a long lasting performance even under diverse environment. It is designed to save up to 70% energy compared to conventional lighting solutions. It comes in high quality material with superior aesthetic looks.

Reliable savings, lasting brightness

High quality material and design

- Finless design with superior aesthetic looks
- Toughened and shatter-proof quality built-in lens enhances safety
- Pressure die-cast housing offers excellent corrosion-resistance and robustness

Long-lasting performance

- Designed for energy savings of up to 70%
- 50k hours operation
- Designed for operations under diverse environment from -10°C to 45°C

Uniform lighting

- Street light distribution with uniform lighting on the street

Technical specifications

Type	BRP 052
System Wattage (W)	40
IP Rating	IP65
Lumen Output (lm)	3600
System Efficacy (lm/W)	90
Color Temperature (K)	5700
CRI	70
Housing	LM6 high pressure die cast aluminium
Cover	Glass
Mounting	Side entry with OD 32-40mm
THD	<20%
PF	>0.9
Operating Voltage	140V-270 V AC 50Hz

Note

- All the specifications are nominal values and will have a variation of (+/-10%) at rated voltage of 240V AC
- Other variant's available on requests



Applications

Residential

Security

Parks